

SIGN	DATE	DESCRIPTION	APPROVER
△	2010.03.31	Add the 2p mark	Jacke
<i>THIS IS CAD DRAWING, DO NOT REVISE MANUALLY!!!</i>			

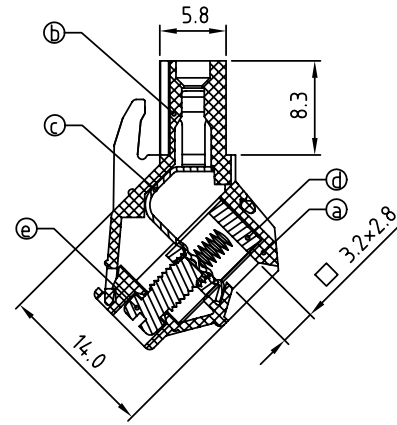

- Material:
- Item (a) Terminal(up body): Thermoplastic (UL94V-0)
 - Item (b) Terminal(down body): Thermoplastic (UL94V-0)
 - Item (c) Female contact: PhBz ,Tin plated
 - Item (d) Clamp: Brass(CuZn) Ni plated
 - Item (e) Terminal screw: Steel Zinc plating "--" slot type

- Electrical: cULus
- Voltage rating:300 V
 - Current rating:20 A
 - Wire range:
 - Solid wire(AWG):12-22
 - Stranded wire(AWG):12-22
 - Torque:4 Lb-In
 - Screw:M3
 - Wire strip length:7-8 mm
 - Withstanding Voltage: 1.6KV
 - Operating temperature:-40°C to +115°C
 - Safety Approval: cULus

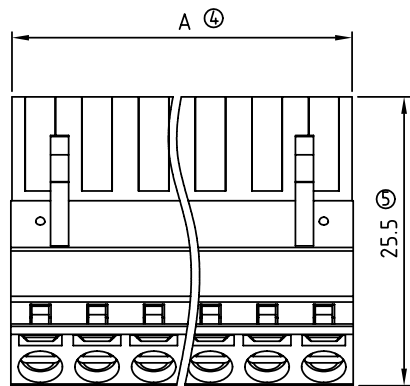

EM xx 7 1 x 0 xxxx G

- No. OF POLES ———— G: Pb<40000ppm
- 02: 2 POLES
- ⋮
- 24: 24 POLES
- Color
- 0 Black (RAL9005)
 - 2 Red (RAL3001/D)
 - 3 Orange(RAL2011/P)
 - 4 Yellow(RAL1018/A)
 - 5 Green(RAL6018/T)
 - 6 Blue (RAL5015/A)
 - 8 Grey(RAL7035/D)
- 0000: "@ " Logo (Standard)
- 000A: "ANYTEK" Mark
- Any special item by customer request. please contact sales department.

POLE		2	3	4	5	6	7	8	9	10	11	12	
A		10.00	15.00	20.00	25.00	30.00	35.00	40.00	45.00	50.00	55.00	60.00	
B		5.00	10.00	15.00	20.00	25.00	30.00	35.00	40.00	45.00	50.00	55.00	
Tol.		±0.15					±0.20						
POLE		13	14	15	16	17	18	19	20	21	22	23	24
A		65.00	70.00	75.00	80.00	85.00	90.00	95.00	100.00	105.00	110.00	115.00	120.00
B		60.00	65.00	70.00	75.00	80.00	85.00	90.00	95.00	100.00	105.00	110.00	115.00
Tol.		±0.25					±0.30						

ANYTEK				CUSTOMER COPY			
ALL RIGHTS RESERVED. REPRODUCTION OR ISSUE TO THIRD PARTIES IN ANY FORM WHATSOEVER IS NOT PERMITTED WITHOUT WRITTEN AUTHORITY FROM THE PROPRIETOR. PROPERTY OF ANYTEK TECHNOLOGY CO., LTD							
TITLE		EM-5.0 W/O Flange Series					
PART NO.		EMxx71x0xxxxG			DWG NO.		8EM0202
APPROVED		CHECKED	DESIGNED	DRAWN	CUST NO.		Tolerance
			Jacke	Jacke			X. ±0.50
			2010.04.01	2010.04.01			X.X ±0.30
							X.XX ±0.10
							X° ±1°
					SHEET: 01/01		REV.: C