

N=Number of contacts
Dimension A&B&C

DIM A	N×10+3.5
DIM B	(N-1)×10
DIM C	(N+2)×10.0

Poles	Tol.	Dim A&B&C
4p		±0.20
5-10p		±0.30
11-24p		±0.40
25-30p		±0.50

SIGN	DATE	DESCRIPTION	APPROVER
△	2006.08.3	Screw torque value changed from 10.4Lb-in to 12Lb-in	梁仁松
△	2006.08.3	Approval changed	梁仁松
△	3/30'09	Structure changed	JODY
△	3/30'09	Temperature changed from -40~105°C to -40~115°C	JODY
△	11/13'12	Change the screw plating specification	Jacky
△	11/13'12	Change the dimensional tolerance	Jacky
△	11/13'12	Add the dimensional label	Jacky
△	08/25'14	The dimensional tolerance is changed from 17.4±0.30 to 17.4 ^{+0.80} _{-0.30}	Airy min

THIS IS CAD DRAWING, DO NOT REVISE MANUALLY!!!

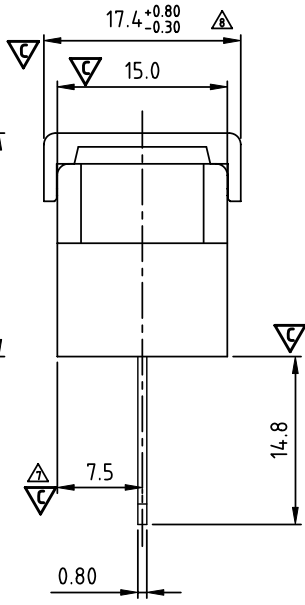
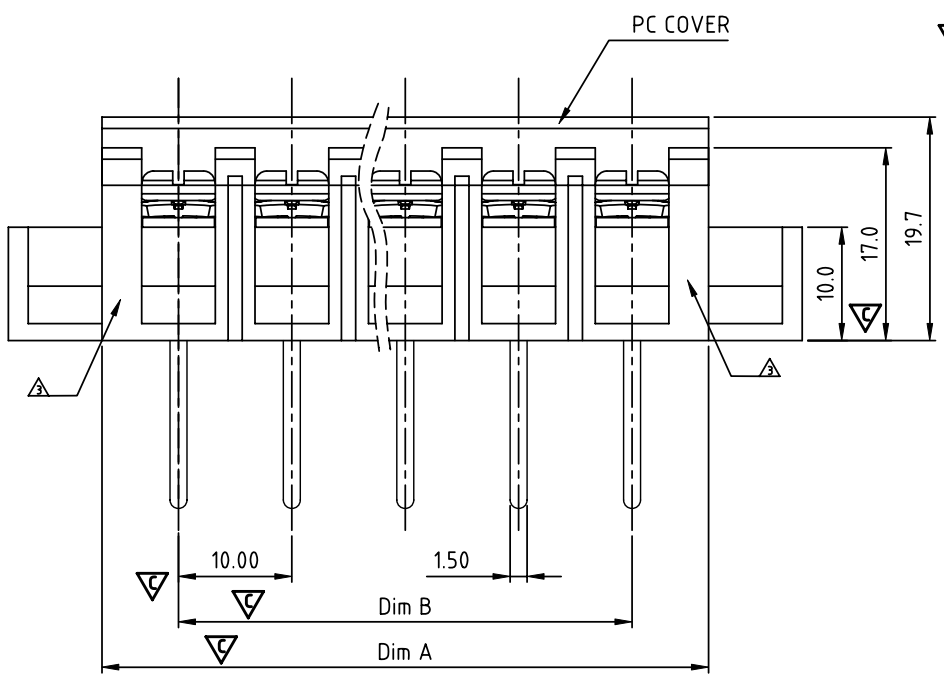

MATERIALS ELECTRICAL
 RATED VOLTAGE & CURRENT: 300 V, 20 A
 WITHSTAND VOLTAGE: AC 2000 V/Min
 INSULATION RESISTANCE: 1000 MΩ OR MORE AT DC 500 V
 OPERATING TEMPERATURE RANG: △ -40 °C ~ +115 °C
 △ SCREW TORQUE VALUE: 12Lb-In.
 WIRE RANGE: 22 - 12 AWG
 1) MOLDED PARTS: POLYIMIDE 66, UL 94 V-0 BLACK
 2) TERMINAL: BRASS, 0.8t, Tin PLATED
 3) TERMINAL SCREWS: STEEL, M3.5
 4) COVER MATERIAL: PC

APPROVAL: us
 Critical dimension:
 PART No.:

YK602 xx 1 x x 00G

NO. OF POLES
 04: 4 POLES
 05: 5 POLES
 06: 6 POLES
 ...
 30: 30 POLES

G:RoHS compliant(lead<4%)
 in copper alloy
 MARK
 0: "@" MARK
 1: "ANY" MARK
 TERMINAL & SCREW PLATED
 0: TERMINAL & SCREW: G/F
 △ 1: TERMINAL: G/F, SCREW: Zinc
 2: TERMINAL: Sn, SCREW: G/F
 △ 3: TERMINAL: Sn, SCREW: Zinc

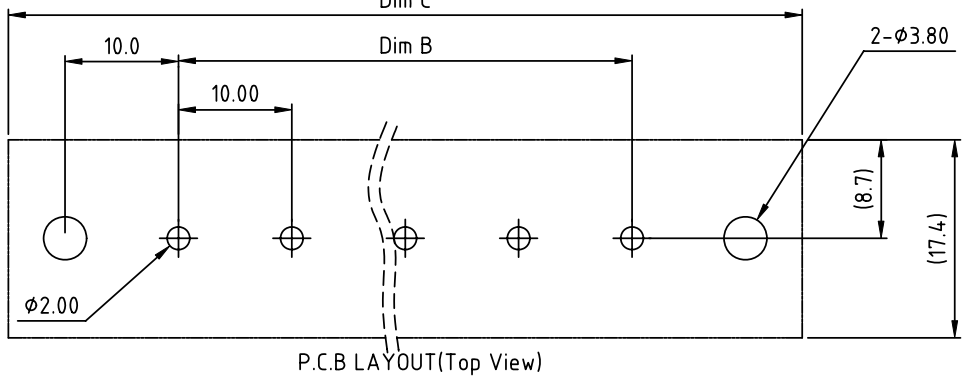

ANYTEK				CUSTOMER COPY		
ALL RIGHTS RESERVED. REPRODUCTION OR ISSUE TO THIRD PARTIES IN ANY FORM WHATSOEVER IS NOT PERMITTED WITHOUT WRITTEN AUTHORITY FROM THE PROPRIETOR. PROPERTY OF ANYTEK TECHNOLOGY CO., LTD						
TITLE		YK-602 With Flange&With Cover Series(4-30P)				
PART NO.		YK602xx1xx00G		DWG NO.		8YK0001-602
APPROVED		CHECKED	DESIGNED	DRAWN	CUST NO.	
			Airy min	Airy min		
			2014.08.25	2014.08.25		
					Tolerance	
				UNIT: mm	X. ±0.50	
				SCALE: NONE	X.X ±0.30	
				SHEET: 01/01	X.XX ±0.10	
				REV.: F	X° ±1°	