

SIGN	DATE	DESCRIPTION	APPROVER
△			
THIS IS CAD DRAWING, DO NOT REVISE MANUALLY!!!			

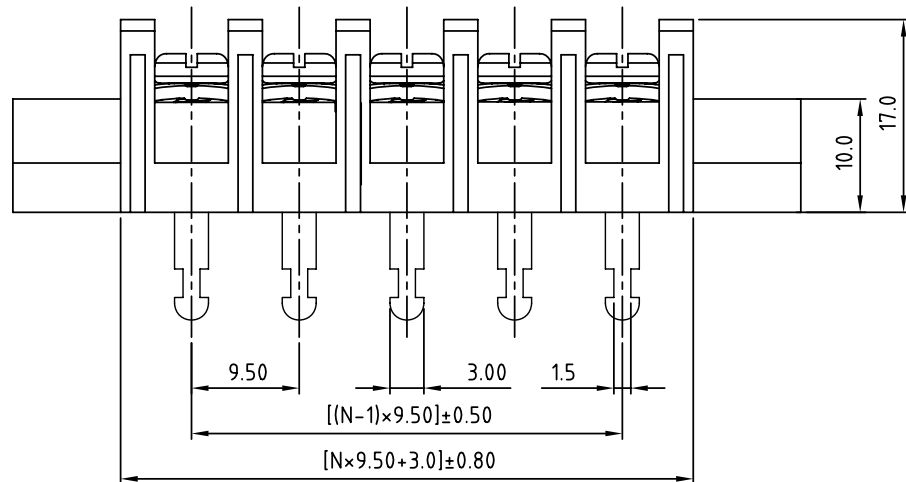
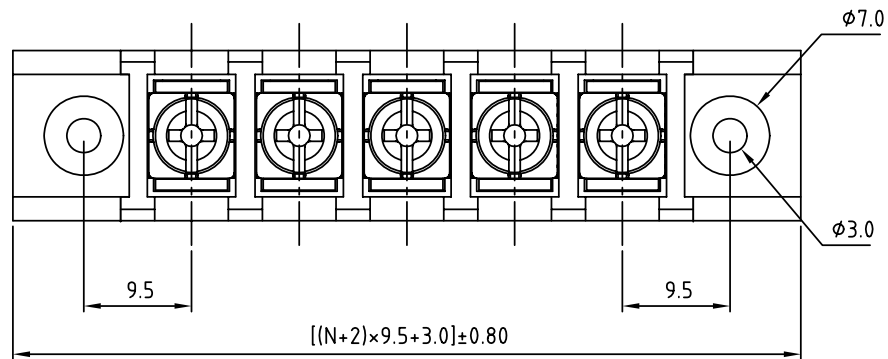

N=Number of contacts

MATERIALS ELECTRICAL
 RATED VOLTAGE & CURRENT: 300 V, 20 A
 WITHSTAND VOLTAGE: AC 2000 V/Min
 INSULATION RESISTANCE: 1000 MΩ OR MORE AT DC 500 V
 OPERATING TEMPERATURE RANG: -40 °C ~ +115 °C
 SCREW TORQUE VALUE: 12 Lb-In.
 WIRE RANGE: 22 - 12AWG
 1) MOLDED PARTS: POLYIMIDE 66, UL 94 V-0 BLACK
 2) TERMINAL: BRASS, 0.8t, Tin PLATED
 3) TERMINAL SCREWS: STEEL, Ni PLATED, M3.5

APPROVAL: us

PART No.:

YK506 xx 3 x x 00G

NO. OF POLES
 02: 2 POLES
 03: 3 POLES
 04: 4 POLES
 ...
 30: 30 POLES

G: Pb<40000ppm

MARK
 0: "@" MARK
 1: "ANY" MARK

TERMINAL & SCREW PLATED
 0: TERMINAL & SCREW: G/F
 1: TERMINAL: G/F, SCREW: Ni
 2: TERMINAL: Sn, SCREW: G/F
 3: TERMINAL: Sn, SCREW: Ni

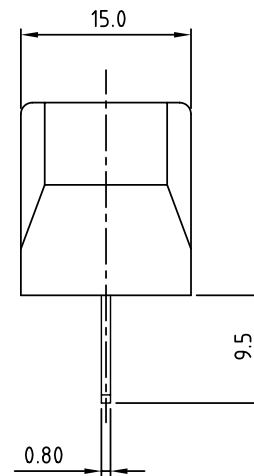

ANYTEK

CUSTOMER COPY

ALL RIGHTS RESERVED. REPRODUCTION OR ISSUE TO THIRD PARTIES IN ANY FORM WHATSOEVER IS NOT PERMITTED WITHOUT WRITTEN AUTHORITY FROM THE PROPRIETOR. PROPERTY OF ANYTEK TECHNOLOGY CO., LTD

TITLE		YK-506 With Flange & Without Cover Series				
PART NO.		YK506xx3xx00G		DWG NO.		8YK0003-506
APPROVED	CHECKED	DESIGNED	DRAWN	CUST NO.		Tolerance
		Tony	Tony			X. ±0.50
		2006.08.03	2006.08.03			X.X ±0.30
						X.XX ±0.10
						X° ±1°
				SHEET: 01/01		REV.: B