



Dimension A&B

DIM A	N×5.08
DIM B	(N-1)×5.08

N=Number of contacts

Poles	A&B Tolerance
2P-8P	±0.15
9P-14P	±0.25
15P-20P	±0.35
21P-24P	±0.40

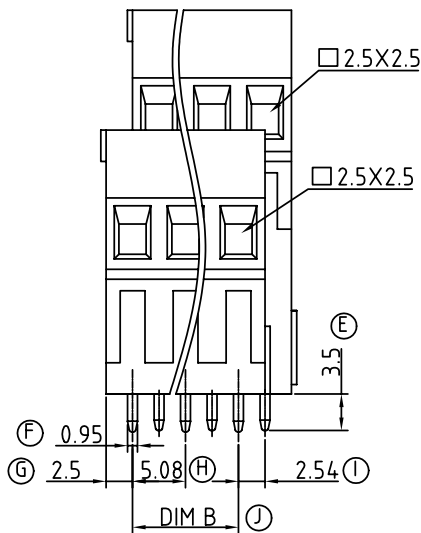

N=Number of contacts



P.C.B LAYOUT



SIGN	DATE	DESCRIPTION	APPROVER
△	01/18'07	Soldering temperature changed from 245° to 250°	Tason
△	01/18'07	Part NO is Changed	Tason

THIS IS CAD DRAWING, DO NOT REVISE MANUALLY!!!

Material:

- Item 1 Terminal housing :Thermoplastic (UL 94V-0)
- Item 2 Clamp : Brass ,Ni plated
- Item 3 Wire guard solder pin : Brass ,Tin plated
- Item 4 Terminal screw : Steel Zinc plating"-slot type

Electrical

- Voltage rating: 300VAC
- Current rating: 10A
- Wire range:
 - Solid wire(AWG): 12-24
 - Stranded wire(AWG): 12-24
- Torque(Lb-In): 3.5
- Screw: M2.5
- Wire strip length: 6-7mm
- Withstanding Voltage: 1.6KV
- Operating temperature: -40°C to +115°C
- Soldering temperature: 250°C±10°C/5 Sec
- Safety Approval: US

△ YM xx 41 x 0 xxxx G

- 04 2×2 CONTACTS
- 06 2×3 CONTACTS
-
- 48 2×24 CONTACTS

- 0 Black
- 5 Green
- 6 Blue
- 8 Grey

0000:"@”Logo (Standard) Pb < 40,000ppm
 000A:"ANYTEK”Logo (RoHS)
 Any special item by customer request, please contact sales department.

ANYTEK		CUSTOMER COPY	
ALL RIGHTS RESERVED. REPRODUCTION OR ISSUE TO THIRD PARTIES IN ANY FORM WHATSOEVER IS NOT PERMITTED WITHOUT WRITTEN AUTHORITY FROM THE PROPRIETOR. PROPERTY OF ANYTEK TECHNOLOGY CO., LTD			
TITLE	YM-5.08mm -L Series		
PART NO.	YMxx41x0xxxxG	DWG NO.	8YM0101
APPROVED	CHECKED	DESIGNED	DRAWN
		Aaron 2009.11.30	熊海霖 2007.01.25
SHEET: 01/01		UNIT: mm	X. ±0.50
		SCALE: NONE	X.X ±0.30
		REV.: D	X.XX ±0.10
			X° ±1°