

N=Number of contacts

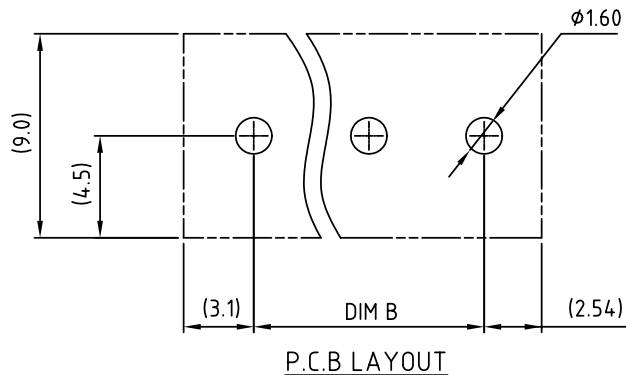

P.C.B LAYOUT

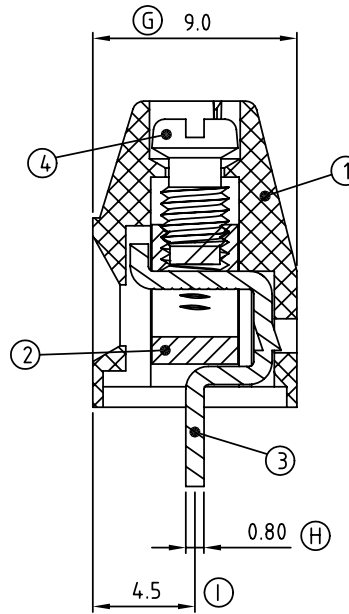

Dimension

DIM A	Nx5.08
DIM B	(N-1)x5.08

N=Number of poles

POLES	TOL
2p-6p	±0.15
7p-12p	±0.25
13p-16p	±0.35
17p-24p	±0.40

SIGN	DATE	DESCRIPTION	APPROVER
△	8/07'06	Added FIMKO standard	梁仁松
△	01/18'07	Soldering temperature changed from 245° to 250°	Tason
△	01/18'07	Part NO is Changed	Tason

THIS IS CAD DRAWING, DO NOT REVISE MANUALLY!!!

Material:

- Item 1 Terminal housing :Thermoplastic (UL 94V-0)
- Item 2 Clamp : Brass ,Ni plated
- Item 3 Wire guard solder pin : Brass ,Tin plated
- Item 4 Terminal screw : Steel Zinc plating"-slot type

△ Electrical cULus/FIMKO

- Voltage rating: 300VAC/300VAC
- Current rating: 16A/17.5A
- Wire range: 0.5~1.5mm²
- Solid wire(AWG): 12-28
- Stranded wire(AWG): 12-28
- Torque: 3.5Lb-In./0.5Nm
- Screw: M3
- Wire strip length: 6-7mm
- Withstanding Voltage: 1.6KV/2.5KV
- Operating temperature: -40°C to +115°C
- Soldering temperature: 250°C±10°C/5 Sec
- Safety Approval:

△ VI xx 21 x 2 xxxx G

02 2 CONTACTS	0 Black	0000:"@Logo (Standard)	Pb < 40,000ppm
03 3 CONTACTS	5 Green	000A:"ANYTEK"Logo	(RoHS)
... ..	6 Blue	Any special item by	
24 24 CONTACTS	8 Grey	customer request,	
		please contact sales	
		department.	

ANYTEK

CUSTOMER COPY

ALL RIGHTS RESERVED. REPRODUCTION OR ISSUE TO THIRD PARTIES IN ANY FORM WHATSOEVER IS NOT PERMITTED WITHOUT WRITTEN AUTHORITY FROM THE PROPRIETOR. PROPERTY OF ANYTEK TECHNOLOGY CO., LTD

TITLE		VI 5.08 SERIES 180° wire inlet (without cover)			
PART NO.		VIxx21x2xxxxG		DWG NO.	8VI0103
APPROVED	CHECKED	DESIGNED	DRAWN	CUST NO.	
		Aaron 2009.06.17	Aaron 2009.06.17		
				Tolerance	
				UNIT: mm	X. ±0.50
				SCALE: NONE	X.X ±0.30
				SHEET: 01/01	X.XX ±0.10
				REV.: F	X° ±1°