

Note: 3P Cover for odd poles
2p Cover for even poles

10.5

Dim.L

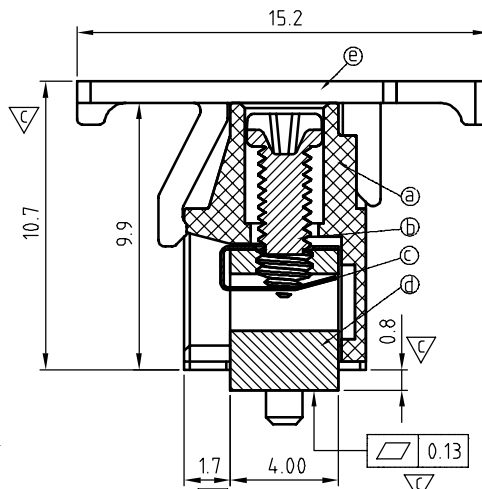

SECTION A-A

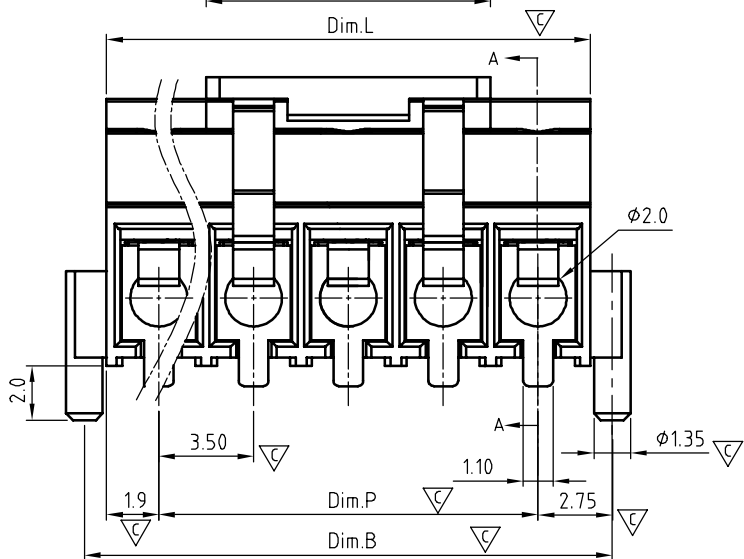

Dim.P

Dim.B

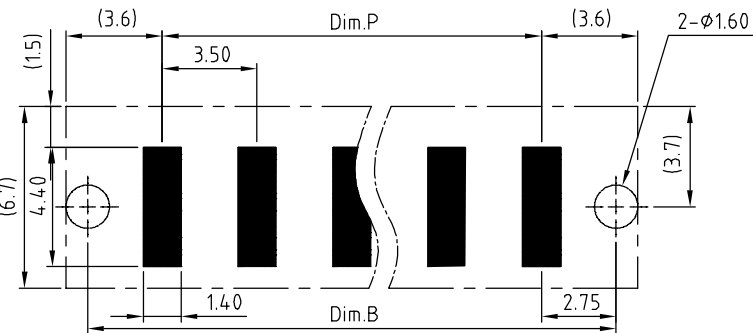

P.C.B LAYOUT

N = Number of poles
 $Dim.L = N \times 3.5 + 0.35$
 $Dim.P = (N - 1) \times 3.5$
 $Dim.B = (N - 1) \times 3.5 + 5.5$

Dim. Poles	Dim.L	Dim.P	Dim.B
2-6p	± 0.25	± 0.20	± 0.20
7-12p	± 0.30	± 0.25	± 0.25
13-16p	± 0.35	± 0.30	± 0.30

SIGN	DATE	DESCRIPTION	APPROVER
△	04/05`12	Operating temperature is changed from -45°C to +130°C to -45°C to +65°C	Guoxue
△	04/05`12	The PART NO is changed	Guoxue
△	04/05`12	The Material is changed	Guoxue

THIS IS CAD DRAWING, DO NOT REVISE MANUALLY!!!

Materials

- △ Item ① Terminal body: High temp. polyamide (UL94V-0)
- Item ② Terminal screw: Steel Zinc plating "+/-" slot type
- Item ③ Wire guard: Stainless steel
- Item ④ Terminal: Brass (CuZn) Tin Plated
- Item ⑤ Terminal Cover: High temp. polyamide (UL94V-0)

Electrical UL

- Voltage rating: 150VAC
- Current rating: 10A
- Wire range:
 - Solid wire (AWG): 16-26
 - Stranded wire (AWG): 16-26
- Torque (Lb-In): 2.0
- Screw: M2.0
- Wire strip length: 5-6mm
- Withstanding Voltage: 1.6KV
- Operating temperature: -45°C to +65°C
- Soldering temperature: 280°C/10 Sec
- Safety Approval:
 - Critical dimension: ∇
 - Part No:

△ EC xx 10 x 1 Bxxx G

Solid block
 02 2 POLES
 03 3 POLES
 ...
 16 16 POLES

COLOR
 0 Black (RAL9005)

B00A "◎" Logo
 B00A "ANY" Logo
 ...
 Any special item by customer request, please contact sales department

RoHS compliant (lead<4%)
 In copper Alloy

ANYTEK

CUSTOMER COPY

ALL RIGHTS RESERVED. REPRODUCTION OR ISSUE TO THIRD PARTIES IN ANY FORM WHATSOEVER IS NOT PERMITTED WITHOUT WRITTEN AUTHORITY FROM THE PROPRIETOR. PROPERTY OF ANYTEK TECHNOLOGY CO., LTD

TITLE		EC 3.5 Series "+/-" Screw With pillar (With cover & tape reel)	
PART NO.		ECxxx10x1BxxxG	
DWG NO.		8EC0007	
APPROVED	CHECKED	DESIGNED	DRAWN
		Guoxue 2012.07.28	Guoxue 2012.07.28
CUST NO.		SHEET: 01/01	
		Tolerance	
		UNIT: mm	
		SCALE: NONE	
		X. ±0.5	
		X.X ±0.3	
		X.XX ±0.1	
		X° ±1°	